

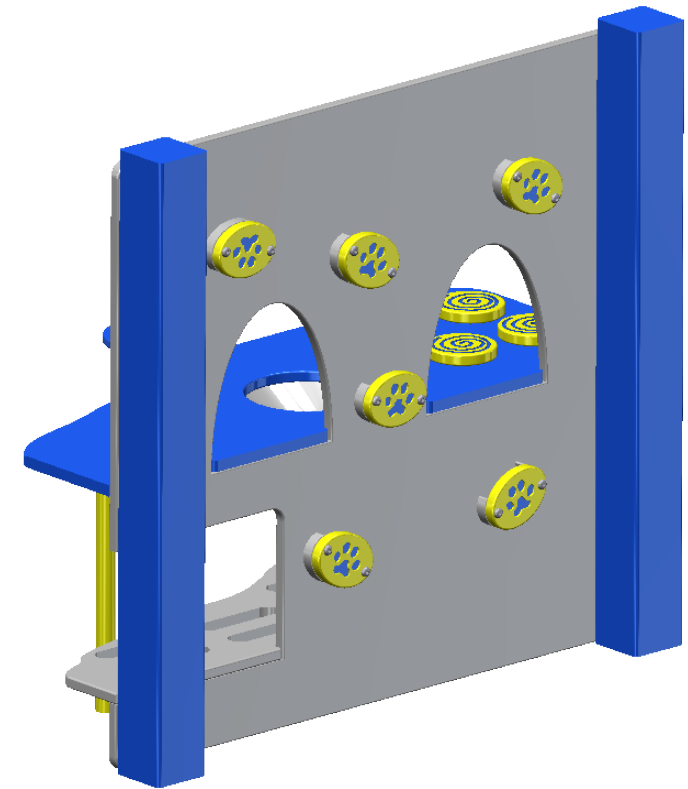

23 ch. Boom Lane, Unit/Unité E Industrial  
 Park/Parc industriel Atholville, New/Nouveau-  
 Brunswick Canada, E3N 4E8  
 Tel/tél. : 1-888-212-1411/Fax/télec. : 1-888-  
 789-0987 www.kangoroo.com



**KITCHENETTE-ASS**

Min. Protective Surface Required / Surface de protection min. requise  
 . m ("") x .m ("")

CAN/CSA-Z614

Recommended Ages / Âges recommandés :  
 months to years old / mois à ans

Equipment Dimensions / Dimensions de l'équipement :  
 m ("") x m ("")

Capacity / Peut accueillir : up to 30 children / Jusqu'à 30 enfants

Approval date: 2022-07-18

Rev: 00

Initial: S.T



23 ch. Boom Lane, Unit/Unité E Industrial  
 Park/Parc industriel Atholville, New/Nouveau-  
 Brunswick Canada, E3N 4E8  
 Tel/tél. : 1-888-212-1411/Fax/télé. : 1-888-  
 789-0987 www.kangoroo.com

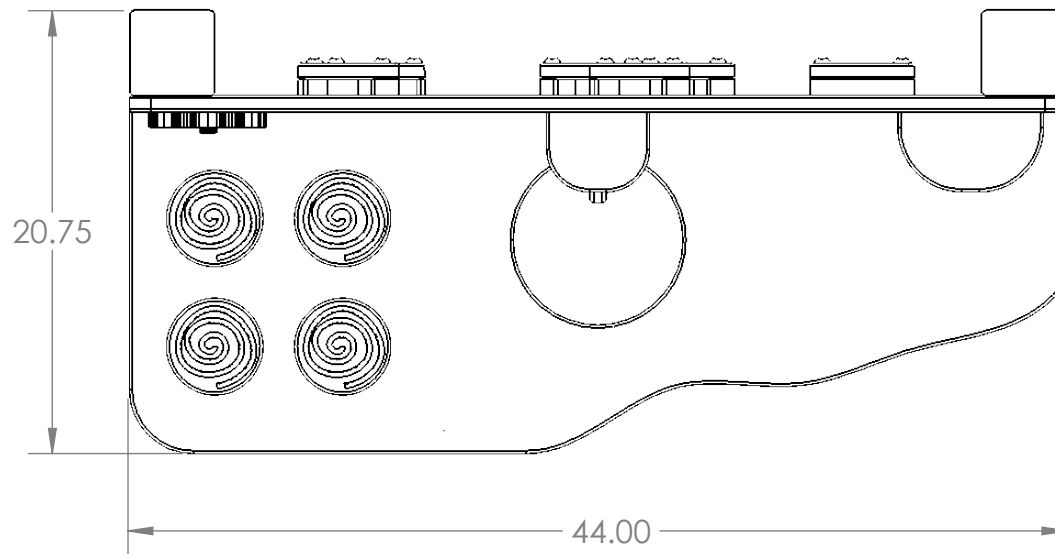

<b>KITCHENETTE-ASS</b>	Min. Protective Surface Required / Surface de protection min. requise . m ("") x .m ("")	Equipment Dimensions / Dimensions de l'équipement : m ("") x m ("")	Approval date: 2022-07-18 Rev: 00
CAN/CSA-Z614	Recommended Ages / Âges recommandés : months to years old / mois à ans	Capacity / Peut accueillir : up to 30 children / Jusqu'à 30 enfants	Initial: S.T